



# NEWS RELEASE

# NMPRA

NATIONAL MINATURE PYLON RACING ASSOCIATION INC.

→ FORMULA I → QUARTER MIDGET →

AUGUST 1978

AMA AFFILIATED

SINCE 1965

<b>President:</b>	<b>Bob Smith</b> P. O. Box 543 Chatsworth, Ca. 91311	<b>Secretary:</b>	<b>Gary McPike</b> 22247 YBarra Road Woodland Hills, Ca. 91367
<b>Q. M. President:</b>	<b>G. E. Jacobson</b> Lt. Col. USAF Retired 2205 Britley Terrace College Park, Georgia 30349	<b>Q. M. Editor:</b>	<b>George Zink</b> 80-28 222 St. Jamaica, N. Y. 11427
<b>Editor:</b>	<b>Jeff Bertken</b> 4136 Lake Harbor Lane Westlake Village, Ca. 91361	<b>Treasurer:</b>	<b>Ron Schorr</b> 5224 Teesdale Ave. No. Hollywood, Ca. 91607

## PRESIDENTS PAGE

Well, our Season is already half over with most areas showing a slight increase in entries. Our N. W. District, under V. P. Leadership of Vince Caluri, is really alive again with over 20 New Members. Vince has been promoting Racing alot and it's really paying off, nice job. Resent correspondence with the Tuson R/C CLUB shows that they might have Formula I at the winter Nats again. Anyone who thinks they might attend Please let me know.

Plans for the NMPRA Championship Race, co-sponsored by the Dallas R/C Club, the NMPRA and R/C Modeler Magazine are taking shape. Race Headquarters will be at the Sheraton Inn, Northeast at 11350 LBJ Freeway at Jupiter. Registration will begin at noon Friday, October 20th. and will end at 6:00 P.M. Scale judging will be in the Grand Ballroom. A complete safety and specifications check will precede static judging. At 7:00 P.M. on Friday. Entry is by invitation only. To receive an invitation, you must place in the top 20% in points in your district or minimum of 10 or top 10 places at the AMA Nationals or be an NMPRA officer. These qualifications will be strictly adhered to. Custom blended fuel by Phil Bussell, nationally known speed flier, and new F-I pilot, will be available by advance request only.

Racing will begin at 8:00 A.M. on October 21st. The banquet will be held at 7:30 P.M. the same evening. For information contact one of the following:

Ed Rankin, Contest Director  
6072 Wonder Dr.  
Ft. Worth, Texas 76133  
817-292-0465

Randy Kent, Contest Manager  
2709 Marbella Dr.  
Dallas, Texas 75228  
214-270-1688

Well it's off to beautiful sunny Lake Charles Louisiana, see ya next month.

Bob

FROM THE SECRETARY

Attention: V. P.s It appears that there has been some confusion about how many races are counted for District and National points the magic number is six. At the end of the racing year you should count the best six races for all your racers. Also, we have not gotten point standings for four of the districts. I know racing is going on out there but the only results we've gotten are from the western district, south central east and south east.

There is not much else to write about this month. I hope you are trying to put that old equipment back into circulation and getting some new blood into racing!

Good Racing

Gary McPike

BOB REUTHER



**HOBBY WORLD**

Quality R. C. Products

6602 Hwy. 100 • Nashville, Tenn. 37205

356-1225

Call Day or Night

352-1450



"MATCHED PERFORMANCE SYSTEMS"  
K & B ENGINES • K & B FUELS • K & B GLOW PLUGS

"MATCHED FINISH SYSTEMS"  
K & B SUPER POXY PAINTS • K & B FIBERGLASS  
K & B SUPER POXY RESIN  
K & B MICRO BALLOONS FILLER

12152 SO. WOODRUFF AVE., DOWNEY, CALIF. 90241

The NMPRA wishes to congratulate Eric Ristrim for his outstanding win in standard class at Santa Clara. Eric established his eligibility as a top caliber race pilot. It is with great pleasure and pride that we welcome Eric into the rank of "Expert". (10 first places, 1:26 1:25, 1:25.4, 1.25.9, 1.22.9, and 1:19.5)!!! Look out!!!

Congratulations to Bob Smith for a well deserved win in expert class at Santa Clara. Bob had a fast time of 1:15.4 in taking the top spot of the contest.

Jeff Bertken (Mr. BB and Jr.) set fast time at Santa Clara with a 1:12.9 in the 6th round. Congrats Jeff. Now lower!!!

SANTA CLARA

EXPERT

1. Bob Smith 1:15.4
2. Tom Christopher 1:15.0
3. Ed Allen 1:15.3
4. Ron Schorr 1:16.7
5. Dave Shadel 1:14.6
6. Gary Hover 1:17.1
7. Rusty 1:18
8. Mike Helsel 1:14.2
9. Mike Atzei 1:14.4
10. Kent Nogy 1:15.0

STANDARD

1. Eric Ristrim 1:14.5
2. Don Kaylor 1:23.5
3. Mac Moffatt 1:57.5
4. Paul Kenny 1:30.6
5. Chick Bentz 1:36.5
6. L. Walker 1:43
7. Gordon Davis 1:33.6
8. Gary McPike 1:35.4
9. J. Kelly
10. T. Fortier

RACE REPORTS - N. E. DISTRICT

I May 21, 1978 - Niagara Falls, Ontario

1. Chuck Bayer 13 pts. 1:37.0
2. Dave Kelly 13 pts. 1:38.0
3. Hal deBolt 13 pts. 1:39.5
4. Saul Green 11 pts. 2:14.0
5. Kent Landefeld 10 pts. 1:30.0
6. Ed M. Smith 9 pts. 2:21.0
7. Bill Brandow 8 pts. 1:37.2
8. Bob Ball 8 pts. 1:39.2
9. Harry Greenaker 6 pts. 1:43.0
10. Steve Nagy 3 pts. 2:05.0
11. George Baynes 0 pts. NT
12. Ed J. Smith 0 pts. NT

II. June 11, 1978 - Waterford, Ontario

1. Steve Nagy 12 pts. 1:39.0
2. Bob Ball 11 pts. 1:38.0
3. Ernie Nikodem 9 pts. 1:25.0
4. Dick Smith 8 pts. 1:47.0
5. Hal deBolt 7 pts. 1:41.0
6. Kent Landefeld 6 pts. 1:29.0
7. Ed M. Smith 6 pts. 1:53.0
8. Ed J. Smith 5 pts. 2:02.0
9. Saul Green 4 pts. 2:22.0
10. Bill Brandon 3 pts. 2:06.0
11. Harry Greenaker 2 pts. 1:39.0
12. Chuck Boyer 0 pts. NT
13. Dave Kelly 0 pts. NT
14. George Baynes 0 pts. NT
15. Jim Nikodem 0 pts. NT

**A PROVEN WINNER!**

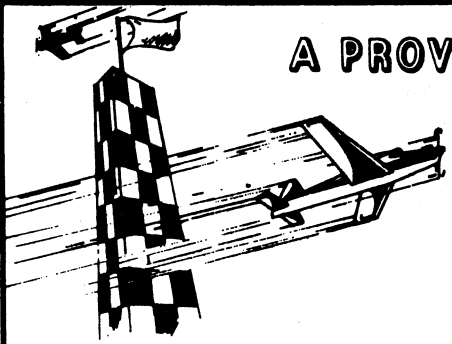

Our R/C systems are made to withstand the extreme stress racing demands—and still give you the high accuracy and response you want.  
Let us put you ahead!

SERIES '77 KP-7C

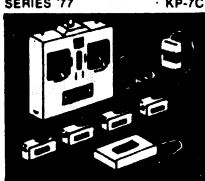

**KRAFT**  
WRITE FOR FREE CATALOG  
488 WEST CALIFORNIA AVE., P. O. BOX 1388  
VISTA, CALIFORNIA 92083 (714) 734-7148

**Radio Control Systems**  
**Futaba**

Futaba Industries, U.S.A./630 W. Carob Street/Compton/CA/90220/ (213) 537-9610

III. June 10, 1978 - Hadley, Massachusetts

1. Pete Reed	20 pts.	1:21.0
2. Bill Zautner	19 pts.	1:21.5
3. Tom Castellano	19 pts.	1:23.0
4. Glenn Sicotte	18 pts.	1:22.5
5. Bob Wallace	13 pts.	1:39.0
6. Gary Dabrowski	11 pts.	1:40.8
7. Kirk Cirillo	10 pts.	1:39.0
8. Arnie Wile	8 pts.	1:35.0
9. Bob Barkowski	7 pts.	1:26.0
10. Jack DePace	7 pts.	1:39.0
11. Adam Sattler	4 pts.	1:35.5

V. June 25, 1978 - Jamestown, New York

1. Steve Nagy	15 pts.	1:35.0
2. Jim Nikodem	14 pts.	1:36.0
3. Saul Green	13 pts.	2:07.0
4. Hal deBolt	12 pts.	1:38.0
5. Chuck Bayer	12 pts.	1:44.0
6. Bob Ball	10 pts.	1:37.0
7. Ernie Nikodem	9 pts.	1:38.0
8. Terry Scheel	5 pts.	1:34.0
9. Ed J. Smith	5 pts.	1:47.0
10. Kent Landefeld	3 pts.	1:33.0
11. Roy Walder	3 pts.	2:07.0
12. Bill Brandow	0 pts.	NT
13. Rick Paine	0 pts.	NT
14. Dick Smith	0 pts.	NT
15. Dave Kelly	0 pts.	NT
16. Harry Greenaker	0 pts.	NT

IV. June 11, 1978 - Hadley Massachusetts

1. Pete Reed	19 pts.	1:22.5
2. Bill Zautner	19 pts.	1:23.1
3. Glenn Sicotte	18 pts.	1:25.0
4. Arnie Wile	15 pts.	1:25.0
5. Kirk Cirillo	14 pts.	1:27.0
6. Bob Wallace	12 pts.	1:40.0
7. Dan Willard	12 pts.	1:40.0
8. Jack DePace	4 pts.	1:41.0
9. Tom Castellano	8 pts.	1:29.2
10. Brian Belleveau	6 pts.	1:49.6
11. Adam Sattler	4 pts.	1:40.5
12. Gary Dabrowski	0 pts.	NT
13. Bob Barkowski	0 pts.	NT

*The Winning Combination for Pylon Racing.  
The Little Toni and Terry Tigre.*

Available At Your Local Dealer

- World Record Design Little Toni..... \$109.95
- Little Toni Wing Kit..... 38.95
- Little Toni Q.M. Racer..... 79.95
- Toni Q.M. Wing Kit..... 26.95
- Joined Epoxy Wheel Pants (Formula I)..... 9.95
- Joined Epoxy Wheel Pants (Q.M.)..... 7.95
- Axle Retainers - Formula I (Med.)..... 1.98
- Axle Retainers - Q.M. (Small)..... 1.79
- Heavy Duty Dural Gear - Formula I Med..... 5.95
- Heavy Duty Dural Gear - Q.M. Small..... 4.95

Available Direct Only

- Customize your S.T. X-40 (Must be new)..... \$90.00
- S.T. X-40 Rear Exhaust Extension..... 5.00
- S.T. X-40 Exhaust Adapter "O" Rings - Pkg. 3..... 1.50
- S.T. X-40 Drive Washer Puller..... 10.00
- S.T. X-40 Bar Stock Exhaust Adapter (1 1/2" Angle)..... 8.00
- Rossi Rear Exhaust Extension - Unslotted..... 5.50

 **PRATHER PRODUCTS**

1660 Ravenna Ave., Wilmington, Ca. 90744 • (213) 835-4764



# THE HOBBY MARKET

P.O. BOX 2172, 3934 W. VICKERY, FT. WORTH, TEXAS 76101  
~~PH. (817) 731-0444~~

**RACING HEADQUARTERS**

**YOU NEED IT! WE GOT IT!**

PRATHER PRODUCTS

A & L LRJA

CT EL BANDITO

STAFFORD RICKY RATS

K&B & SUPERTIGRE ENGINES

HOUSE OF BALSAs Dara & Shoestring

SKYGLASS Minnow

Dara & Cosmicwind



**CALL US!**

## VALLEY FLYERS FORMULA I RACE

The Sepulveda Basin was the site of the second Valley Flyers Formula I race of the year held 8 & 9 July. There were 20 entries in Expert, six of which were on 72.160 MHz and 12 entries in Standard, four of which were on 72.40 MHz. The usual Saturday morning crashes reduced the field considerably but did not help the frequency pileup. Three or less plane heats were all that was possible for rounds 6, 7 and 8 which were flown Sunday morning.

In the last round, Ed Hotelling, Tom Christopher and Bob Smith all met head to head with Ed being one point ahead of Bob at the time. Bob's airplane, which he borrowed from Laird Owens, was obviously slower and after three laps of extremely tight flying, Ed and Tom gradually pulled away from him. Ed was the winner of the heat and the race and also had the fast time of 1:16.7. Bob Smith was second overall, Jeff Bertken was third and Jerry Boyce beat Dave Shadel in a flyoff for fourth and fifth when Dave's engine quit. The best crash award went to Bob Williams.

In Standard, Russ Kime flamed out in the last round and still had enough points to win with Don Kaylor, second; Joe Stream, third; Mack Moffat, fourth; Gary McPike, fifth. Gordon Davis, turned in a respectable 1:31 during one of the few times he was able to keep his engine running for ten laps. Trophies were awarded to the top five in each division and the Perpetual American Aircraft Modeller 4 foot trophy is now taking up half of Carol Hotelling's living room. It was heard after the race that it is unfair for Ed to have a wife that could call Pylon I as close as Carol can.

George W. Finch, C.D.

### EXPERT

1. Ed Hotelling	1:16.7*
2. Bob Smith	1:20.1
3. Jeff Breatken	1:17.6
4. Jerry Boyce	1:21.0
5. Dave Shadel	1:17.0
6. Ron Schorr	
7. Joe Zdankiewicz	1:29.5
8. Len Ledson	1:29.0
9. Ron Gilman	1:18.6
10. Tom Christopher	1:18.9

### STANDARD

1. Russ Kime	1:27.0
2. Don Kaylor	1:28.5
3. Joe Stream	1:30.4
4. Mac Moffatt	1:36.5
5. Gary McPike	
6. Steve McCann	
7. Chick Bentz	1:36.5
8. Gordon Davis	1:31.9
9. Gene Sidwell	1:37.0
10. Tony Amezcua	1:37.2

\* Fast time

### BRIDI HOBBY ENTERPRISES

1611 E. Sandison St.  
Wilmington, CA  
90477

(213) 834-0801

## HOBBY BARN

### DISCOUNT PRICES

P. O. BOX 17856 TUCSON  
ARIZONA 85731  
Call (602) 747-3633  
For all your racing needs.

\*\*\*\*\*  
America's Largest Fiberglass Kit Manufacturer.  
Helping Support Racing For Years.  
AT-6 Racing - try it in your area!

## PYLON REPORT FROM NORTHWEST DISTRICT

June 17th. & 18th. 1978

Boundary Bay Field.

Four classes of racing were held on the weekend with a total of 49 entries from B.C., Alberta, Washington & Idaho. Saturday morning saw 15 flyers compete in Sport Pylon and in the afternoon 10 flyers went a little faster to compete in Open Pylon.

Sunday morning saw a change in wind direction and flying start was needed in the Quarter Midget race as these small planes won't take off in a strong downwind. 9 flyers competed in this event. After Quarter Midget the Formula I flyers took to the sky. 15 flyers in all and some very close racing was seen.

### QUARTER MIDGET

1st. George Soderberg (CALGARY)	Mustang	Cox
2nd. Andrew McIndoe (RCFCBC)	Toni	Rossi
3rd. Jim Pepperdine (CALGARY)	Rickey Rat	Cox
4th. Don Rice (SEATTLE)	Lria	Cox
5th. Al Livesey (RCFCBC)	Toni	Rossi
6th. Bill Moorhead (SEATTLE)	Folkets	Cox
7th. Walt Chickmoroff (CALGARY)	Mustang	Cox
8th. Doug Rankin (RCFCBC)	Rickey Rat	Cox
9th. Vince Calouri (SEATTLE)	Mustang	Rossi

FAST TIME: Andrew McIndoe 1:41

### FORMULA I

1st. Walt Reiss (IDAHO)	El Bandito	X40
2nd. Greg Simpson (RCFCBC)	Polecat	X40
3rd. Bob Hunt (SEATTLE)	Denight	X40
4th. Doug Rankin (RCFCBC)	Toni	K & B
5th. Guy Johnson (RCFCBC)	Toni	X40
6th. Joe Gauthier (RCFCBC)	Toni	K & B
7th. Len Yuen (RCFCBC)	Toni	K & B
8th. Nelson Eddy (SEATTLE)	Toni	X40
9th. Gord Van Tighan (CALGARY)	Estralita	K & B
10th. Barrie Berlin (CALGARY)	Pallats	K & B
11th. Larry Eckersley (RCFCBC)	Toni	X40
12th. Vince Calouri (SEATTLE)	Midget Mustang	X40
13th. Don Rice (SEATTLE)	Pole Cat	K & B
14th. Al Livesey (RCFCBC)	Toni	X40
15th. Andrew McIndoe (RCFCBC)	Toni	X40

FAST TIME: Walt Reiss 1:20 (WOW!)

MVRC 2 Races  
May 20-21, 1978  
C.D. Foster Goshorn  
Formula I

1. Bill Hager 1:12
2. Bill Johanson 1:15.5
3. Foster Goshorn 1:17.6
4. Wayne Yeager 1:36
5. Bob Hisey 1:30.2
6. Joe Cohen

7. Fred Johanson
8. Art Arro
9. D. Bebensee
10. Barney Polzin
11. Rex Knepper

DPC Pylon Races  
June 10-11  
Dayton, Ohio  
C.D. Bill Hager

1. Bill Hager 1:18.4
2. Bill Johanson 1:41.3
3. Wayne Yeager 1:31.5

4. Dave Keats 1:22.7
5. Fred Johanson 1:32.6
6. Bob Hisey
7. Art Arro
8. Ken Hulik

9. Barney Polzin
10. Jim Cunningham
11. Rex Knepper
12. Joe Cohen

3rd. Annual Pontiac Chiefs R/C Club Pylon Race  
May 28, 1978  
Chatsworth, Illinois

1. Bill Pries 1:25.87
2. Bob Onori 1:34.38
3. Steve Metzger 1:28.94
4. Roger Schlenker 1:39.83

5. Jack Clark 2:00.87
6. Dennis Bielick
7. Frank Morosky

8. Charles Brunner
9. Jim Gager
10. Lynn Stevens

Radio Control Club of Detroit  
5th. Annual  
June 24-25

1. B. Hager 1:19.5
2. W. Yeager 1:30
3. R. Knepper 1:29.5
4. M. Lasker 1:43
5. B. Johanson 1:47

6. B. Mellen
7. D. Keats
8. A. Arro
9. D. Bebensee
10. B. Hisey

11. J. Krauer
12. B. Polzin
13. J. Cohen
14. V. Scanland

Fort Wayne Flying Circuits Pylon Race  
July 8-9  
C.D. James Gager

1. Bill Pries 123:22
2. Dave Keats 123:90
3. Bill Hager 121:22
4. R. Onori 126:72
5. C. Brunner 127:43
6. B. Polzin

10. M. Lasker
11. B. Ruther
12. B. Hisey
13. R. Metzger
14. D. Bielick
15. W. Yeager

19. B. Johanson
20. A. Grove
21. D. Latsha
22. F. Johanson
23. F. Goshorn
24. J. Cohen

7. R. Schlenker  
8. K. Hulik  
9. G. Jacobson

16. A. Arro  
17. A. Booth  
18. R. Knepper

25. J. Clark  
26. B. Adams

## RESULTS FROM SEMPRA

May 27 and 28 races in Atlanta, Georgia

1. John McDermott
2. Bob Brodgon
3. Brille Richmond
4. Bob Reuther
5. Jim Maki
6. Bill Helms
7. Bill Williamson
8. Harold Coleson
9. Gail Jacobson
10. Irwin Funderburk
11. Dallas Buck
12. Greg Doe
13. Bruce Richmond
14. Wayne Stanley

Fort Wayne, Indiana

July 8-9

This Contest turned out to be the best attended of the year with 45 entries in Q.M. and 26 in Formula I.

There was cash on the line for this one-\$250.00 for first place, \$150.00 for second and \$100.00 for third. We have been talking about money races for quite some time. Well here we had one. \$250.00 is nothing super, but it should at least pay for the winner's expenses with a little left.

The weather both days was sunny, hot and humid with very little wind. So the weather was on our side. We all got in two full days of racing.

At the close of this contest the C.D. was over heard saying that this was the last one. No more racing at Ft. Wayne. WHY??? The race was well attended. They had plenty of spectators and the club made a lot of money. So then why?

From the drop of the first flag on Saturday to the last race on Sunday the C.D. did nothing but listen to gripes and complaints from the flyers and callers. While at every contest there are times when people do make mistakes and there will always be a few arguments. But constantly for two days? Why? Do people change that much over a few hundred dollars?

I have been working pretty hard in the area to promote racing and when we loose a contest I try to find out why. We need more races not less. I believe when a C.D. or his workers, who he is responsible for, goofs they deserve some of the lumps they get. But at this contest there was not justification for two days of abuse.

Maybe money is not the way to go. I am not sure what the answer is. But we better think on it strongly.

Bill Hager



NMPRA WESTERN DISTRICT 5 Races

July 20, 1978

1. D. Shadel	491.2	(E)	
2. B. Smith	491.1	(E)	
3. T. Christopher	482.8	(E)	
4. G. Hover	433.6	(E)	
5. E. Allen	413.1	(E)	
6. M. Atzei Jr.	386.2	(E)	
7. R. Schorr	378.6	(E)	
8. J. Stafford	376.6	(E)	
9. J. Bertken	357.3	(E)	
10. L. Ledson	342.0	(E)	
11. B. Williams	335.0	(E)	
12. J. Kimbro	288.4	(E)	(4)
13. J. Boyce	278.7	(E)	(4)
14. J. Rouse	260.9	(E)	(4)
15. B. Wilde	259.8	(E)	(4)
16. R. Van Baren	258.8	(E)	(4)
17. D. Rubie	215.0	(E)	(4)
18. K. Nogy	201.9	(E)	(3)
19. M. Mitchell	197.4	(E)	(3)
20. E. Hotfilling	190.3	(E)	(2)
21. M. Helsel	187.7	(E)	(2)
22. J. Zdankiewicz	183.7	(E)	(2)
23. D. Kaylor	167.2	(S)	
24. L. Owens	154.6	(E)	(2)
25. R. Sheldon	145.3	(E)	(2)
26. C. Bentz	139.9	(S)	
27. S. Johnson	133.1	(E)	(2)
28. R. Kime	128.2	(S)	(4)
29. G. McPike	119.2	(S)	(4)
30. L. Leonard	112.4	(E)	(2)
31. L. Laulom	110.9	(E)	(2)
32. M. Moffatt	99.4	(S)	(4)
33. J. Stream	95.2	(S)	(3)
34. E. Ristrim	95.1	(S)	(3)
35. J. Brodbeck Jr.	95.1	(E)	(1)
36. T. Prather	93.5	(E)	(1)
37. G. Sidwell	82.2	(S)	(4)
38. H. Condra	79.9	(E)	(1)
39. R. Gilman	77.7	(E)	(1)
40. G. Davis Jr.	74.7	(S)	(4)
41. R. Hadaway	62.8	(E)	(1)
42. R. Raymond	57.7	(E)	(1)
43. T. Amezcua	56.0	(S)	(4)
44. R. Farrier	54.9	(S)	(2)
45. T. Sato	46.1	(S)	(3)
46. J. Replogle	39.3	(S)	(1)
47. L. Walker	39.2	(S)	(2)
48. M. Franklin	38.9	(E)	(1)
49. P. Benezra	37.8	(E)	(1)
50. J. Coffman	30.5	(S)	(1)

51. B. Baker	26.1	(S)	(1)
52. S. McCann	25.3	(S)	(2)
53. R. Jones	24.0	(S)	(1)
54. B. Bailey	23.2	(S)	(1)
55. P. Kinney	22.4	(S)	(1)
56. S. Smithwick	15.9	(S)	(1)
57. B. Ballowe	14.9	(S)	(1)
58. G. Farish	13.3	(S)	(1)
59. R. Janiger	7.3	(S)	(1)
60. J. Kelley	4.5	(S)	(1)
61. J. Ross	4.3	(S)	(1)
62. L. Watson	2.7	(S)	(1)
63. D. Ficucell	2.4	(S)	(1)
64. T. Fortier	1.2	(S)	(1)
65. J. Martin	1.2	(S)	(1)

(E) - Expert

(S) - Standard

(1) - Denotes races attended, if not listed, all five contests were attended.

Points compiled by G. McPike, National Secretary.

#### QM - PRESIDENTS MESSAGE

Having been to several contests this year, four out of the past five weekends, I'm convinced that the hardest job of all is that of the C.D. He has all of the problems most of them defy solution. Everybody just can't be right or pleased. Probably the most thankless job goes to the workers who give up their weekend to put on a contest for a bunch of guys they don't know and who may come storming down to no. 1 pylon trying to get a cut undone or something similar. The C.D.s and workers most of the time take it and try to work the problems out. When the race is over many of them wonder if it was worth it. If some races are not held next year then the contestants who fussed and fumed are probably responsible.

Probably the largest contest this year will be the Fr. Wayne, Indiana contest. About 45 1/4 midgets and 28 or so Form Is. An excellent contest and well run. I have been told that two-thirds of all NMPRA members live within 600 miles of Fr. Wayne. Possible Championship race for 1/4s and Forms? Their hospitality also rates 4 stars.

Most of you know of Murphys laws and probably wish he would take his laws to another country but at the Eastern States Championships ole Murphy got beat. It seems that a contestant started his engine for the second race of the day when he noticed that the carb. was falling out. The engine was stopped to tighten the bolt but the bolt but the bolt was gone. A rubber band was looped around the nose of the 1/4 midget and over the carb. The engine restarted and needle valve had to be reset. With the carb. jumping around the plane took off and won the race. The same guy went on to win the Eastern States Championships. Those of you who missed this race missed a great one. Another four stars.

QM SECTION

1980 AMA Rule Proposals

Gail Jacobson, President of NMPRA-QM, has submitted four rule proposals to the AMA. If you have any comment about any of the proposals, please write either Jake or myself.

#1. Delete all of paragraph 15.1 and replace with:

Starting positions in all races shall be determined by random flagged off as soon as possible.

#2. Change Paragraph 5.2 Exhaust Extractors, to read:

An unslotted exhaust may be used provided its sole purpose is to carry exhaust fumes and residue out of the cowling. The exhaust extension must be of constant diameter not over four inches long or as provided by the engine manufacturer as a stock part. Any part of the exhaust extension may continue outside the cowl.

#3. (General Proposal) Delete the first paragraph of the Supplemental and Provisional Rules beginning with the words: The rules specifically indetified . . . and replace with:

The rules specifically identified as supplemental and provisional do not qualify as "official" model aircraft regulations of the Academy of Model Aeronautics. Provisional rules will automatically be upgraded to "Official" status when that event is included as an event in the National Model Airplane Championships.

#4. (General Proposal) Add to paragraph 19, Interpretation of Regulations in the general section: For National competition, the Nationals Event Director may change, add or modify a rule, or rules subject to the approval of the appropriate special interest organization as defined in paragraph 3.7. Special Interest Organizations may specify to their event director rules changes, additions or modifications. Event rules changed in this manor will be forwarded to the appropriate contest board for their information and use.

Don't let this stop you from submitting your own proposals. If you see rules which QM should have in 1980, by all means write them out and send them to the AMA. The AMA has a procedure for changing the rules and the first step is to get one of their forms. The forms are available from AMA and a copy of it was printed in a recent Model Aviation magazine issue.

. . . . .

Gail Jacobson also sent in the following tip for CD's.

"I have been told that a Cox 15 barrel will fit in a Rossi 15 Carb. The Cox 15 barrel is a few thousands larger that the Rossi, or good for 7-800 RPM. A good visual inspection will detect the difference."

. . . . .

QUALIFICATION HEATS AND RACE SCHEDULES: These shall be the same as the AMA Scale Class-Radio Control Pylon Racing (Goodyear Racers).

That's it - the Quarter Midgets for 1968-69. This is another of the fast growing events that can be either measured, timed or counted. This is an event that does not depend on the judge to determine the winner. One that does not require long hours of costly building or practice.

An event, that is in fact, open to anyone that wants to give it a try! We hope you will

. . . . .

Thanks again Chuck for doing the groundwork and creating the basic rules of Quarter Midget. Your vision has given many of us real pleasure and satisfaction in the last 10 years.

It was a real revelation to me, reading Chucks rules. I was struck by some of the differences we have today, sure, but you can still see the real basics there and that only goes to show how good the rules were when they were first proposed.

Thanks again to Dick Tichenor and the people at RMC for sending us the article.

## RACE RESULTS

CPPRA, Lehigh, PA July 2, Hardy Johnson CD.

Pl.	Pilot	Aircraft	Engine	Best Time	Av. Time
1.	Lew Hipkins	Toni	C	1:40	1:47
2.	Ron Bressler	LR-1A	C	1:42	1:48
3.	Bob Blouch	Blouch P-51	R	1:42	1:48
4.	Paul Zink	Ricky Rat	R	1:35	1:40
5.	Dave Latsha	Toni	C	1:36	1:42
6.	Dave Hidden	Lil Quickie	R	1:45	1:54
7.	Dick Beltz	P-39	C	1:47	1:52
8.	Warren Batson	Toni	C	1:50	1:54
9.	Tom De Groot	Lil Gem	C	2:29	2:50
10.	Al Grove	Toni	C	1:45	1:49
11.	Dick Berner	Toni	C	1:50	1:51
12.	Arthur Talisman	P-51	R	2:02	1:51
13.	Frank Heil	Toni	Cf	1:44	1:54
14.	Herb Adams	P-51	C	2:22	2:27
15.	Patrick Ray	Lil Gem	ST	2:38	2:45
16.	Tom Dooley	Rickey Rat	R	2:25	2:31
17.	Dick White	Proud Bird	C		

Idle rule and slotted pipe rule waived. QM Rule 19, 1 point award to participants of aerial contact (Bobby Blouch & Paul Zink) used. Flyoff used to determine 2nd place.

### QM SECTION

From the pages of the Control Line Speed and Racing GAZETTE, which, by the way we highly recommend, comes the following.

"ROSSI .15

Note: The all new Rossi 15 is expected very soon. This engine is 1500RPM faster than the 1977 version. We will have them just as soon as they arrive in the U.S. If you want to be sure to get one as soon as possible, we suggest that you place a \$20.00 deposit. Standard, piped and R/C versions will be available in either stock or custom tuned configuration. The custom R/C model will pass 1/4 Midget inspection."

About that was a definition of stock and custom tuned engines as given by the distributor.

### Stock and Custom Tuned Engines

Custom tuned engines will undergo considerable rework. Exact modification will vary, however, if you desire a general description of the procedures involved, or if you have any other question, please send a letter together with a stamped, self addressed, return envelope. When ever you order a custom tuned engine, it is most important that you specify exactly how you intend to use the engine. Head spacing and other tolerances will vary quite considerably depending upon the intended use of the engine.

Since the above could be construed by some to be an advertisement, unpaid at that. I will withhold the name and address of the writer. I will send you the info if you ask and include a self addressed stamped envelope. Might as well comment on it if you want too.

We have been very happy with our subscription to the GAZ and we do recommend it to anyone with a more than passing interest in engines and props.

## CONTEST RESULTS

Willow Lake Pylon Club, Okla. City, Okla., June 10, Dave Harter, CD

Pl.	Pilot	Aircraft	Engine	Best Time	Points
1.	Rodger Schlenker	P-51		1:57	
2.	Charles Monnet	Swee Pee		2:01	
3.	Don Downing	Midget Mustang		1:53	
4.	Jack Clark	P-63		1:45	
5.	Dan Lewis	Mustang		2:16	
6.	Parks-Bussell Team	Lil Pogo		1:49	
7.	Pat Jones	Miss DARA		1:48	
8.	Larry Barnes	Swee Pee		2:02	
9.	Steve Vaughn	Minnow		2:08	
10.	Keith McClure	Cosmic Wind		2:10	
11.	Jerry Small	Midget Mustang		1:54	
12.	Bill Feiertag	Shoestring			
13.	Albert Taffs	Rickey Rat			
14.	William Jehle	Ballerina			
15.	Clyde Young	Miss DARA			
16.	Richard Brunken	Rickey Rat			

2 mi. course, Idle rule enforced, No slot required. 30 mph winds.

## QM RACE RESULTS

June 4 1978 Falcon Air Races Ann Arbor Mich. Keith Shaw CD.

Pl.	Pilot	Aircraft	Engine	Best Time
1.	Tom Dudan	Toni	C	1:36.4
2.	Duane Gall	Miss Paranoia	R	1:41.2
3.	Douglas Bebensee	Miss Paranoia	R	1:47.8
4.	Ben Marin	Miss Paranoia	R	1:40.5
5.	Wayne Yeager	Proud Bird	R	1:42.5
6.	Dave Keats	Toni	R	1:38.6
7.	Dave Martin	Toni	R	1:43.0
8.	Mario Biscaro	Miss Paranoia	R	1:43.8
9.	John Fotiu	Miss Paranoia	R	1:39.9
10.	Joe Cohen	Miss Paranoia	C	1:54.2

Report submitted by Art Arro AVP:QM/NCE.

Art says that the day was beautiful, a warm sunny one with light breezes. Both the slot and the idle requirement were dropped. The course length was 2 miles and the racing was fast and furious as evidenced by those good times.

## Q. M. SECTION

### Contest Results:

Dayton Pylon Club Races, Dayton, Ohio, Bill Hager CD.

Pl.	Pilot	Aircraft	Engine	Best Time	Points
1.	Duane Gail	Miss Paranoia	R	1:36	18
2.	Ben Martin	Toni	R	1:33	17 *
3.	Wayne Yeager	Proud Bird	R	1:44	17 *
4.	Joe Cohen	Miss Paranoia	R	1:37	16 1/2
5.	Dennis Sumner	Toni	R	1:37	16 *
6.	Mario Biscaro	Miss Paranoia	R	1:46	16 *
7.	Barney Polzin	Miss Paranoia	R	1:33	15
8.	Dave Martin	Toni	R	1:39	14 1/2
9.	Dave Keats	Toni	R	1:42	12 1/2
10.	Dan Kane	Toni	R	1:33	11 1/2
11.	LeRoy Webb	Toni	R	1:48	11
12.	Tom Dudan	Toni	C	1:36	10 1/2
13.	Ken Heatlie	Toni	R	1:51	8 1/2
14.	Tom Hottell	Toni	R	<u>1:33.3</u>	8
15.	John Kilsdonk	Miss Paranoia	R	1:46	7
16.	Mike Edwards	Toni	R	1:49	3
17.	Allen Booth	Estrellita	R	-	-

That's a 2 mile course, and those times look pretty good to me.

5th. Annual RCCD Pylon Races, Detroit Mich, June 24-25 Dave Keats CD.

Pl.	Pilot	Aircraft	Engine	Best Time	Points
1.	Denis Sumner	Toni	R	1:42	19 *
2.	Doane Gall	Miss Paranoia	R	1:42	19 *
3.	Doug Bebensee	Miss Paranoia	R	<u>1:39.0</u>	16 *
4.	Wayne Yeager	Proud Bird	R	1:48	16 *
5.	Barney Polzin	Miss Paranoia	R	1:46	16 *
6.	Dave Timcoe	LR-1A	R	1:41	11
7.	Ken Heatlie	Toni	R	1:49	11
8.	John Krauer	Miss Paranoia	R	1:54	11
9.	John Kilsdonk	Miss Paranoia	R	1:43	9
10.	Joe Cohen	Miss Paranoia	R	1:42	8
11.	Mario Biscaro	Miss Paranoia	R	1:52	6
12.	Tom Montroy	Miss Paranoia	R	2:19	4

May 28 3rd. Annual Pontiac Chiefs Pylon Race Illinois LeRoy Webb CD.

Pl.	Pilot	Aircraft	Engine	Best Time
1.	Dan Kane	Toni	R	1:40.1
2.	Bill Roland	Toni	R	1:34.8
3.	Floyd Fitzgerald	Toni	R	1:39.3
4.	Jim Gager	Toni	R	1:39.3
5.	Bob Nelson	Bugatti	C	1:40.9
6.	Jack Clark	P-63	R	1:51.6
7.	Russel Orr	Toni	R	1:59.2
8.	Doug Smith	Toni	R	1:49.1
9.	Bob Petrinec	Ballerina	R	1:56.9
10.	Todd Leslie	Toni	R	2:00.2
11.	LeRoy Webb	Toni	R	1:57.1
12.	Lynn Stevens	Toni	R	1:37.1
13.	Roger Schlenker	P-51	C	1:40.5
14.	Denis Bielick	Toni	R	1:44.2
15.	Ken Brieler	LRIA	R	2:14.6
16.	Tom Dudan	Toni	R	1:59.5
17.	Charlie Cappis	Toni	R	1:42.4
18.	Dave Sears	Midget Mustang	C	1:36.4
19.	Brent Rodgers	Toni	R	2:39.8
20.	Kevin Nelson	Bonanza	Fox	2:25.2
21.	Blake Deal	LRIA	C	2:39.5
22.	Mary Wolf	Toni	C	

NORTH CENTRAL EAST NMPRA POINTS JULY 10, 1978

Name	NMPRA #	#of Contests	Total Points
1. Bill Hager	55P	4	380.2
2. Wayne Yeager	5W	4	279.2
3. Bill Pries	23P	2	195.4
4. Bob Onori	41V	2	173.0
5. Art Arro	73W	4	160.0
6. Barney Polzin	14W	4	144.6
7. Roger Schlenker	70W	2	140.5
8. Rex Knepper	33P	4	126.5
9. Steve Metzger	99E	2	126.4
10. Fred Johanson	67N	3	116.7
11. Charles Brunner	29U	2	107.8
12. Dennis Beilik	16U	2	91.8
13. Foster Goshorn	4N	2	88.8
14. Gail Jacobson	18Q	1	70.0
15. Joe Cohen	20W	4	66.7
16. Bob Reuther	44S	1	61.9
17. Jack Clark	93W	2	57.4
18. Allen Booth	78V	1	37.6
19. Al Grove	11N	1	25.5
20. David Latsha	7N	1	21.4
21. Jim Gager	78U	1	11.4
22. William Adams	45V	1	1.2

Q M SECTION  
Race Results

QMRC, May 21, Sepulveda Basin, L.A. California

Pl.	Pilot	Points	Best Time
1.	Kent Thomas	18	1:39
2.	Bob Nickle	16	<u>1:27.5</u>
3.	Bob Gillespie	15	1:45
4.	Larry Jolly	14 1/2	1:45
5.	Bob Root	12 1/2	1:37
6.	Eloy Marez	12	1:37
7.	Lance Roberts	12	2:04
8.	Bob Novak	11 1/2	1:41
9.	Tom Christopher	11	<u>1:28</u>
10.	Bobby Gillespie	9 1/2	2:20
11.	Lonnie Roberts	8 1/2	1:36
12.	Ron Russell	8	1:35
13.	Dave Robertson	7 1/2	1:45
14.	Larry Laulom	7	1:36
15.	Jim Lime	7	1:57
16.	John Reid	4	2:07
17.	Mel Santmyers	3	1:52

78 AMA rules were used with the following changes: No slots required, no flagmen at #1 pylon and race-horse starts. Bob Nickle's 1:27.5 is the fastest time we have had recorded so far.

QMRC, June 11th. Mile Square. Orange County, Ca.

Pl.	Pilot	Points	Best Time
1.	Bob Root	16	-
2.	Kent Thomas	14	
3.	Ken Tinker	13	
4.	Eloy Marez	12 1/2	
5.	John Creagh	12	
6.	Bob Nickle	11	
7.	Bob Novak	11	
8.	Bob Gillespie	9	
9.	Mel Santmyers	8	
10.	Lonnie Roberts	7	
11.	Bobbie Gillespie	5	
12.	John Reid	4 1/2	
13.	Tony DiPadova	1	

Short Course used, Mufflers were required, no times were sent.  
Above reports were sent in by Bob Gillespie.

Sorry, but we just didn't have enough room for the Drag article this month. Don't forget to get your nominations for QM officers to either Jake or me by August.



Formula I SEMPRA Thru June 1, 1978 (3 races)

Name	# races entered	Points
1. Gail Jacobson	(3)	221.6
2. Bob Brogden	(3)	199.7
3. John McDermett	(2)	191.5
4. Jim Maki	(3)	180.2
5. Dennis O'Brien	(2)	177.5
6. Bill Preis	(2)	169.1
7. Brillo Richmond	(3)	156.1
8. Carl Sims	(2)	147.8
9. Tom Pownell	(2)	145.4
10. Bill Williamson	(3)	145.1
11. Clyde Yarbrough	(2)	117.5
12. Bob Reuther	(2)	109.7
13. Greg Doe	(3)	108.7
14. Bob Violet	(1)	103.0
15. Dave Pearce	(2)	94.9
16. Bill Heluis	(2)	91.3
17. Bob Silwanicy	(1)	80.4
18. Jim Moorhead	(1)	79.2
19. James Little	(2)	56.7
20. Dave Donat	(1)	53.2
21. Cliff Telford	(1)	50.2
22. Harold Colesm	(1)	45.2
23. Dallas Buck	(2)	35.7
24. Irwin Funderburk	(1)	30.5
25. Bob Schuster	(1)	27.6
26. John Thomas	(1)	11.6
27. Bruce Richmond	(1)	8.5
28. Dave Johns	(1)	6.4
29. Wayne Stanley	(1)	1.2

**BOB REUTHER**



**"MATCHED PERFORMANCE SYSTEMS"**  
 K & B ENGINES • K & B FUELS • K & B GLOW PLUGS

6602 Hwy. 100 • Nashville, Tenn. 37205  
 356-1225 Call Day or Night 352-1450

**"MATCHED FINISH SYSTEMS"**  
 K & B SUPER POXY PAINTS • K & B FIBERGLASS  
 K & B SUPER POXY RESIN  
 K & B MICRO BALLOONS FILLER

12152 SO. WOODRUFF AVE., DOWNEY, CALIF. 90241

Northwest District Standings After Four Races. E I.

	Names		# Races	Points	Best Time
1.	G. Simpson	10X	4	289.6	1:31
2.	R. Hunt	14E	4	285.4	1:26.1
3.	G. Johnson	36X	4	275.5	1:23.4
4.	N. Eddy	46E	4	260.9	1:23.9
5.	W. Reiss	5E	2	194.6	1:20.7
6.	D. Rankin	30X	3	174.3	1:27.2
7.	L. Yuen	8X	4	171.2	1:32.4
8.	R. Cooney	23E	3	168.7	1:25.2
9.	J. Gautier	26X	2	157.8	1:32
10.	A. Livesey	27X	3	156.6	1:39
11.	J. Safarik	7X	1	89.6	1:31
12.	D. Rice	24E	4	80.0	1:36.5
13.	V. Caluori	6E	3	76.9	1:31.9
14.	T. Huber	31E	1	56.1	N. T.
15.	M. Bryan	7E	1	42.8	1:39
16.	A. McIndoe	41X	3	32.5	1:27.1
17.	L. Eckersley	16X	1	21.8	1:41
18.	M. Stiffon	11X	1	19.1	N. T.
19.	J. Booker	3X	1	11.5	N. T.
20.	R. Kent	18E	1	11.5	N. T.

Vince Caluori

# MODEL MERCHANT'S SUPER QUICKS

## NOW YOU CAN RACE WITH THE BEST OF THEM

### SUPER QUICK

Q-500 RACER



ORDER NO. 114

**\$69<sup>95</sup>**

**SPECIAL FEATURES**

- 1) PREASSEMBLED Balsa FUSELAGE
- 2) Balsa PRESHEETED FOAM WINGS WITH SHAPED TIPS AND ALERONS
- 3) PRESHAPED TAIL AND CONTROL SURFACES

### KING COBRA P-63

15 SIZE SPORT SCALE



ORDER NO. 115

**\$49<sup>95</sup>**

**SPECIAL FEATURES**

- 1) PREASSEMBLED DETAILED FUSELAGE
- 2) UNIQUE REMOVABLE CANOPY HATCH
- 3) Balsa PRESHEETED FOAM WINGS

### POGO

QUARTER MIDGET RACER



ORDER NO. 111

**\$69<sup>95</sup>**

**SPECIAL FEATURES**

- 1) Balsa PRESHEETED FOAM WINGS
- 2) PRESHAPED TAIL AND CONTROL SURFACES
- 3) LIGHTWEIGHT EPOXY GLASS FUSELAGE AND COWL

### RICKY RAT (Pylon Racer)

1/2 A-SPORT SCALE

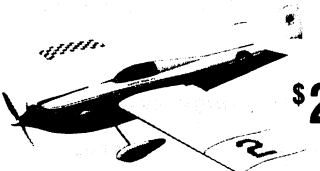

ORDER NO. 101

**\$24<sup>95</sup>**

**SPECIAL FEATURES**

- 1) PREASSEMBLED SCALE DETAILED FUSELAGE
- 2) NEW AND UNIQUE SHEET FOAM WINGS
- 3) NO PAINTING REQUIRED

### MIDGET MUSTANG QM

QUARTER MIDGET RACER



ORDER NO. 112

**\$69<sup>95</sup>**

**SPECIAL FEATURES**

- 1) FOAM WINGS PRESHEETED Balsa
- 2) TAIL AND CONTROL SURFACES PRESHAPED
- 3) EPOXY GLASS FUSELAGE AND COWL

### SUPER MIDGET MUSTANG II

FORMULA ONE

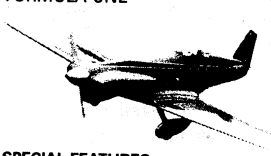

ORDER NO. 113

**\$99<sup>95</sup>**

**SPECIAL FEATURES**

- 1) SPECIAL LAMINAR FLOW WING WITH TWIST FOR HIGH "G" TURNS, HIGHEST UD RATIO
- 2) CONTOURED CANOPY FOR UNDISTURBED FLOW
- 3) LIGHTWEIGHT EPOXY GLASS FUSELAGE

MODEL MERCHANT

**"SEE YOUR NEAREST HOBBY SHOP"**  
 FOR OUR FULL LINE BROCHURE WRITE:  
 P.O. BOX 3792 • IRVING, TEXAS • 75061

# THE SLO FLYERS FORMULA ONE RACE

**PRIZES** EXPERT CLASS - CASH TO 5th PLUS FAST TIME  
 (\$200, 100, 75, 50 and \$100 FAST TIME)  
 STANDARD CLASS - TROPHIES TO 5th PLUS FAST TIME.

LABOR DAY WEEKEND • SATURDAY and SUNDAY • SEPT. 2nd & 3, 1978  
 CAMP ROBERTS AIRFIELD near FAGO ROBLES, CALIFORNIA.

NO REAL AIRCRAFT WILL BE PERMITTED UNLESS SPECIAL ARRANGEMENTS ARE MADE.  
 CAMPING AT AIRFIELD WILL BE OK. UNITS MUST BE SELF-CONTAINED!

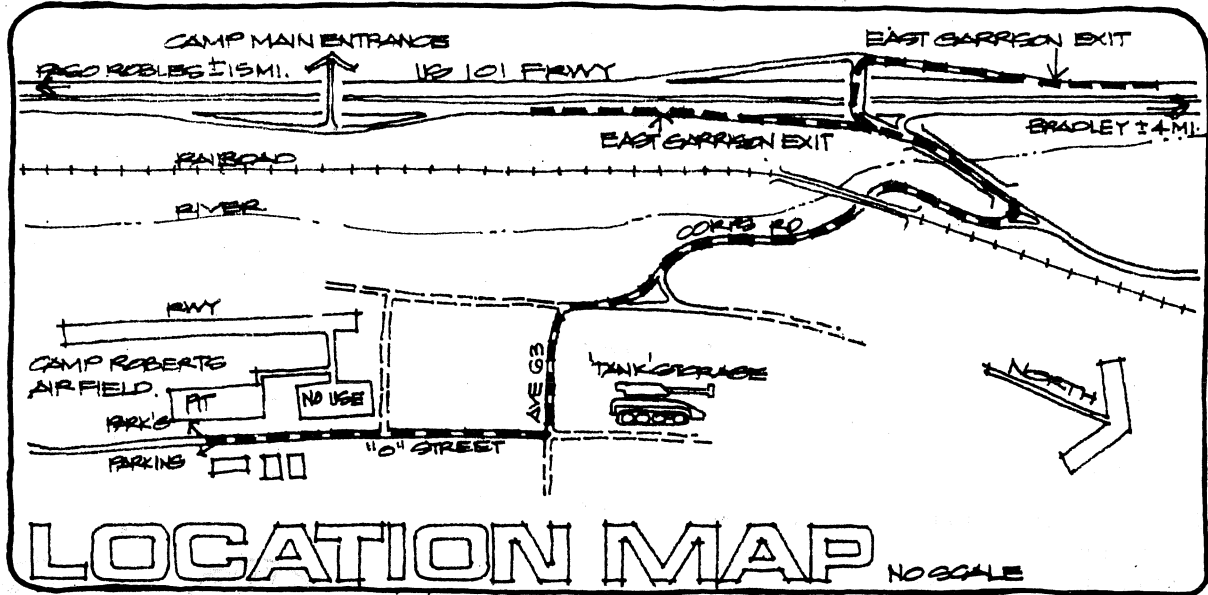

## CONTEST INFO MOTEL

ENTRY FEE EXPERT CLASS \$20.00  
 \* LATE ENTRY \$25.00

ENTRY FEE STANDARD CLASS \$10.00  
 \* LATE ENTRY \$12.50

\* PRE-REGISTRATION REQUIRED - AUG 28, 1978 DEADLINE !!

CONTEST DIRECTOR: GARY HOVER, 1504 16th STREET  
 LOS ANGELES, CA. 90005 • (805) 528-3377

\* REGISTRATION AT FIELD 8:00 AM  
 'SCALE' JUDGING 9:00 AM - FIRST RACE 10:00 AM.

\* NO MORE THAN 25% OF ENTRIES ALLOWED ON ANY ONE FREQUENCY. DATE OF ENTRY WHEN RECEIVED WILL BE USED TO DETERMINE FIRST CHOICE OF FREQUENCY (GET ENTRY IN EARLY)

AS THE COMPETITION IS ON LABOR DAY WEEKEND ROOM RESERVATIONS MAY BE DIFFICULT TO OBTAIN. I HAVE THEREFORE RESERVED A BLOCK OF 20 DOUBLE OCCUP. ROOMS AT THE RAMONA MOTEL APPROX. 4 MILES SOUTH OF FAGO ROBLES ON HWY 101.  
 IF YOU ARE INTERESTED IN A ROOM PLEASE CALL ME IN ADVANCE AS FINAL CONFIRMATION IS REQUIRED. MOTEL HAS PDL, AIR COND. AND TELEPHONES.  
 GARY HOVER.

## ENTRY FORM

MAKE CHECKS PAYABLE TO: THE SLO FLYERS, INC.

NAME \_\_\_\_\_ FREQUENCY \_\_\_\_\_ ALT. FREQUENCY \_\_\_\_\_  
 ADDRESS \_\_\_\_\_  
 CITY \_\_\_\_\_ AMA NO. \_\_\_\_\_ EXPERT \_\_\_\_\_  
 STATE \_\_\_\_\_ ZIP \_\_\_\_\_ FCC LIC. \_\_\_\_\_ STANDARD \_\_\_\_\_  
 PHONE NO. ( ) \_\_\_\_\_ NMPRS NO. \_\_\_\_\_

**LEE CUSTOM ENGINES**  
CUSTOM K & B 40 ENGINES  
for FORMULA I and SCOZZI  
FAN UNITS  
CUSTOM K & B 61 ENGINES  
FOR PATTERN

**C.F. LEE MANUFACTURING COMPANY**  
7215 Foothill Blvd.  
Tujunga, California 91042

N.M.P.R.A NEWSLETTER  
JEFF BERTKEN  
4136 LAKE HARBOR LAND  
WESTLAKE VILLAGE, CA. 91361

FIRST CLASS MAIL



TO:

ED E. RANKIN 1-ER  
6072 WONDER DRIVE  
FT. WORTH, TX. 76133