



NEWS RELEASE

NMPRA

NATIONAL MINIATURE PYLON RACING ASSOCIATION INC.

President:

Bill Hager
706 Glen Haven Dr.
Conroe, TX 77302
(713) 273-2086

QM Exec. & Vice Pres.

Wayne Yeager
38235 Castle Dr.
Romulus, Mi 48174
(313) 941-6661

Treasurer:

Ed Rankin
6072 Wonder Dr.
Ft. Worth, TX 76133
(817) 292-0465

Secretary:

John Jennings
106 Greenway
Sunnyvale, TX 75182
(214) 226-1018

Editor:

Matt Smith
10223 Abraham
Dallas, TX 75227
(214) 285-3579

FEBRUARY 1981

AMA AFFILIATED

SINCE 1965

PRESIDENT'S PAGE

Hi Gang,

Don't forget to vote for the Vice President that you want to represent your District this year. Deadline is February 28, 1981.

The dates for this years Championship race will be October 31, and November 1, 1981. It looks like unless something comes up the race will be held at Las Vegas, sponsared by Circus Circus. I have had a lot of imput and most of it has been positive. We will keep you up to date.

If you haven't already done so it is time to send in your 1981 NMPRA dues. Send them to:

John Jennings
106 Greenway
Sunnyvale, TX 75182

While you are at it get a friend who is interested in racing to join you. Dues are still \$13.00.

Bill

1981 NMPRA MEMBERSHIP APPLICATION FORM

Name: _____ Phone: () _____

Address: _____ City: _____ State: _____ Zip: _____

New Member _____ Renewal _____ 1980 NMPRA No: _____

Racing Interest: Formula 1 _____ QM _____ Both _____

Compete in 1980 ? Formula 1 _____ QM _____ Both _____

Send to John Jennings - 106 Greenway - Sunnyvale, TX 75182

Amount \$13.00 U.S. - Payable to NMPRA

I suppose its winter time in most parts of the U. S. however we've been flying for the last 2 or 3 weekends in shirt sleeves with temperatures in the 60's and 70's. This is all leading up to a report on the 1981 Nationals flying site at Seguin, Texas just north east of San Antonio. The site is an auxilliary Air Force field where jet jockey's practice touch and goes. There should be plenty of room for all events with no problems.

The real reason for our trip to Sequin was a rumor of some interference on certain frequencies. So we loaded up some practice planes and with the use of plug in crystals we checked out the frequencies on 72 mhz. We also checked with a local ham operator and the 53 mhz seems ok also.

The runway proposed for racing is marked on the map. The runways are concrete base covered with asphalt with no seams, holes or any obstructions anywhere.

When I say no obstructions I mean no trees, not but one small building and no shade. If you don't have a tent be sure to get one and bring it.

The average max daily temperature is about 95 (sometimes 100) and low 70's at night with about 55% humidity being on average. Formula 1's should go fast here.

If you need a motel room you better call right now or you won't get one within 30 miles. There are some rooms available in San Marcos, Texas 22 miles north of Seguin. This should be a very good race site.

Matt

NE DISTRICT PRO CIRCUIT RACE SCHEDULE FOR 1981

May 3rd	Hadley	F 1 & Q 500
May 30th & 31st	Thundervolts pattern meet (no scale)	
June 7th	Ware, Mass.	1/2 A & F 500
June 14th	NCRCC Scale	
June 21st	Hadley	Stand off scale & Bi Plane 1/4 scale
June 28th	NCRCC	F 1 & 500
July 11th	NCRCC	F 1 & 500
July 12th	NCRCC	F 1 & 500
July 25th & 26th	Hadley	F 1 & 500
September 20th	Thundervolts	F 500 & maybe FAI

1981 NATS SEGUIN (AUX) FIELD

Seguin climatic data for August:

Temp (avg) Max 95 F (avg. ext. max 100 F)
 Min 73 F

<u>Time</u>	<u>Wind</u>	<u>Humidity (avg)</u>
7 AM	S at 7 (Knots)	/83%
10 AM	S at 8 (Knots)	/62%
1 PM	S at 8 (Knots)	/47%
4 PM	SE at 9 (Knots)	/43%
7 PM	SE at 10 (Knots)	/52%

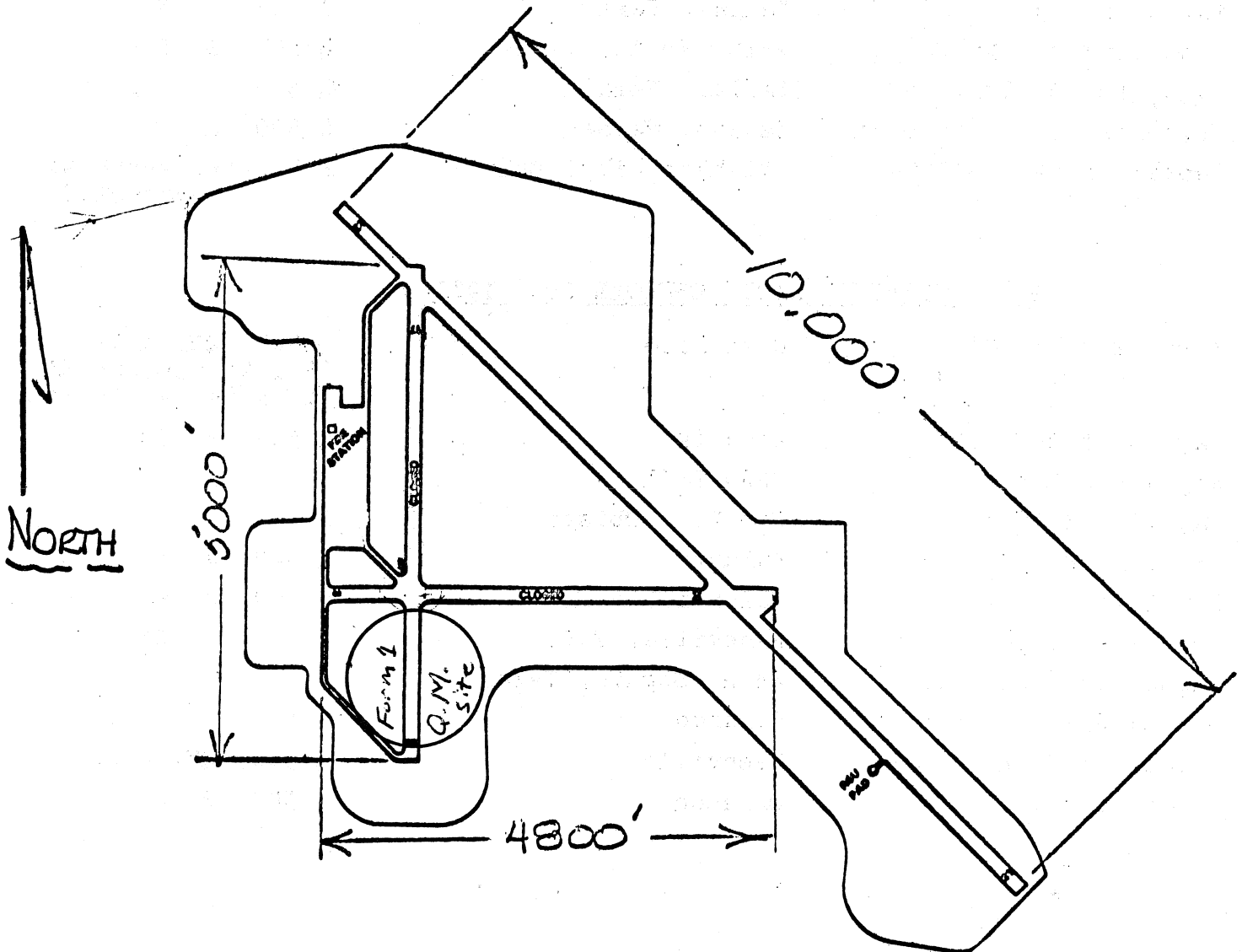

NMPRA WESTERN DISTRICT FORMULA 1 RACE'S FOR 1981

March 28th & 29th	Sepulveda Basin	Valley Flyers
May 16th & 17th	San Luis Obispo	Slo Flyers
June 13th & 14th	Whittier	SGURLL
July 11th & 12th	Whittier	Western Dist NMPRA & BIRDS
August 29th & 30th	Sepulveda Basin	Western Dist (Roll your own)
September 26th & 27th	Bakersfield (Tentative)	Barks
October 31st & Nov. 1st	NMPRA CHAMPIONSHIPS	Las Vegas, Nevada

SWC DISTRICT RACE SCHEDULE FOR 1981

May 3	Oklahoma City, Okla	F 1
May 10th & 11th	Austin, Texas	Q 500 & F 1
May 30th & 31st	Dallas, Texas	Q 500 & F 1
June 13th & 14th	Fort Worth, Texas	Q 500 & F 1
July 11th & 12th	Dallas, Texas	Q 500 & F 1
September 5th, 6th & 7th	Dallas, Texas	Q 500 & F 1
September 19th & 20th	Oklahoma City, Okla	F 1 (two separate contests)

SCE DISTRICT RACE SCHEDULE FOR 1981

April 25th & 26th	Nashville	Q 500, QM, & $\frac{1}{2}$ A (F 1 to replace QM if site available)
May 2nd & 3rd	Atlanta	Q 500 & QM
May 9th & 10th	OPEN DATE	
May 16th & 17th	San Luis Obispo	F 1
May 23rd & 24th	Atlanta	Q 500 & F 1
May 30th & 31st	Columbia, S.C.	Q 500 & $\frac{1}{2}$ A
June 13th & 14th	Asheville, N.C.	Q 500 & QM
August 2nd thur 9th	NATS Seguin, Texas	
September 5th & 6th	Orlando	F 1
September 26th & 27th	Nashville	Q 500, QM, & $\frac{1}{2}$ A
November 1st	Orlando	Q 500 & QM



NMPRA

NATIONAL MINIATURE PYLON RACING ASSOCIATION INC.

Q.M. Executive Wayne Yeager
Vice President 38235 Castle Dr.
 Romulus, Mi. 48174
 313/941-6661

Dont know about you but I'm slightly peeved with the recent A.M.A. Contest Board vote on the QM proposals. Joe Friend indicated he would recommend passage of all proposals on the initial vote leaving us time to try out these ideas and see if any fit in with our plans, however, the C.B. rejection means there is no way to resurect any of these until the two year cycle is over and by then it could be too late, I'm not indicating support of these proposals but they at least deserved a chance for a look-see from us. Personally I think the whole A.M.A. structure stinks whereas 11 people, many of which have no knowledge, or interest in our event, have the power to pass or reject rules we might be in favor of. I think the special interest groups should be the only people who pass or reject rules that concern themselves, and no one else.

The only proposal that passed was Gager's "eliminate carbs, use shut offs with straight venturis" ala Form I. This proposal leaves me with mixed emotions because it obsoletes material currently in use. If there was a venturi availble with the same cross sectional dimensional characteristics as the Perry carbs, then there would be no objection. Anyone with a carb problem could simply change to the straight venturi and we could continue on. The complaints I've heard are, under vibration, the carbs loosen or fall out. You must realize a change to straight venturi's does not gaurantee elimination of that problem. True we are talking metal versus plastic which will probably result in better retention, but no sure thing.

Since there are no venturi's available with the same dimensions as the Perry carbs, the only venturi's available are larger and probably will require pressure. This will result in increased RPM which means, to keep up with the Jones, you will have purchase a straight venturi and throw away your carb. Very simply, passage of this rule obsoletes current material therefore I'm against it. If we want to open up QM to the same unlimited status as Form I, then propose it, but until that time, I say no!

How about you? What do you say? I need some feedback so I can advise the C.B. on the next vote. Write me please..

I've received no correspondence from anyone interested in running for V.P. in NCW, SCW, NW, or SW. Are there no racers out there? How about it guys? Drop me a line.....

Yeager

NMPRA N.E. District Points

AVP Dave Latsha, 1141 Columbus Ave., Lemoyne, Pa. Ph (717) 737-7577

<u>Place</u>	<u>Name</u>	<u>Total N.E. District Points</u>	<u>No. of Races in N.E. District</u>	<u>Eng. of Plane used</u>	<u>Best Time in N.E. District</u>
1	Hal Debolt	225.0	3	Cox/Firecracker	1:38.0
<u>Hal is the North East District Champion</u>					
2	Gary Gau	222.9	4	Cox/Cosmic Wind	1:46.0
3	Bob Blouch	194.6	2	Cox/Blouch Mustang	1:27.6
4	Dave Latsha	181.0	2	Cox/D.L.'s "Rivets"	1:20.5
5	Frank Heil	146.6	2	Cox/Toni	1:45.4
6	Lew Hipkins	121.0	2	Cox/Toni	1:44.0
7	Al Grove	119.2	2	Cox/Toni	1:43.5
8	Vance Sutton	105.4	2	Rossi/Toni	1:48.0
9	Ernie Nikodem	101.5	3	Cox/P-51	1:41.0
10	Len Weiderhoeft	98.5	2	Cox/Shoe String	1:49.0
11	Dick Burner	64.2	2	Cox/Toni	1:38.4
12	John Majikas	50.5	2	Cox/Toni	1:55.0
13	Warren Batson	50.4	2	Cox/Toni	1:52.0

Living out of District Flyers N.E. Points

Wayne Yeager	143.5	2	Cox/Toni	1:37.6
Gail Jacobson	112.2	2	Cox/Pole Kitty	1:25.0
Dave Keats	106.8	2	Cox/LR 1A	1:41.0
Paul Schattaur	71.1	2	Cox/D.L.'s "Rivets"	1:43.1
Dave Timcoe	30.2	1	Cox/Toni	1:44.0

Flew in N.E. District not NMPRA Members

Don Steeb	121.0	3	Rossi/Toni	1:50.0
Jim Nikodem	96.2	3	Cox/P. 51	1:52.5
Dave Thomas	18.0	1	Rossi/Caudron	2:33.0
Chuck Boyer	1.2	1	--	--

All of the above report is for the 1980 Season.

**The Winning Combination for Pylon Racing
The Little Toni and Terry Tigre**

Available At Your Local Dealer

- World Record Design Little Toni..... \$129.95
- Little Toni Wing Kit..... 42.95
- Little Toni Q.M. Racer..... 89.95
- Little Toni Q.M. Wing Kit..... 32.95
- Joined Epoxy Wheel Pants (Formula 1)..... 12.95
- Joined Epoxy Wheel Pants (Q.M.)..... 10.95
- Axle Retainers - Formula 1 (Med.)..... 2.49
- Axle Retainers - Q.M. (Small)..... 2.49
- Heavy Duty Dural Gear - Formula 1 Med..... 5.95
- Heavy Duty Dural Gear - Q.M. Small..... 4.95

Available Direct Only

- Customize your S.T. X-40 (Must be new)..... \$110.00
- S.T. X-40 Rear Exhaust Extension..... 5.00
- S.T. X-40 Exhaust Adapter "O" Rings - Pkg. 3..... 1.50
- S.T. X-40 Drive Washer Puller..... 15.00
- S.T. X-40 Bar Stock Exhaust Adapter (11 1/2" Angle)..... 10.00
- Rossi Rear Exhaust Extension - Unslotted..... 5.50



PRATHER PRODUCTS

1660 Ravenna Ave., Wilmington, CA 90744 • (213) 835-4764

"RIVETS"

Record Q.M. Low Time 1:20.5

D.L.'S. MODELS

'T'-TAIL Q.M. KIT

KIT \$75 DELIVERED - EPOXY GLASS FUSE.

1141 Columbus Ave., Lemoyne, Pa. 17043
Ph. (717) 737-7577 - Free Brochure

RACERS CHOICE: KRAFT

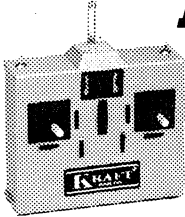

WRITE FOR FREE CATALOG
450 West California Ave.
P.O. Box 1268
Vista, California 92083
(714) 724-7146
TWX: 910 322 1471



LEE CUSTOM ENGINES

Custom versions of all engines in
K & B/Veco line including marine.

C. F. Lee Mfg. Co.
7215 Foothill Blvd.
Tujunga, Calif. 91042

Denight Special F-1
Totally Redesigned Air Frame
\$85.00 Complete Kit
(Less Wing Skins)

Send Orders to:

Gary McPike

28925 Parknath Dr.

Agoura, California 91301

(213) 991-6293 After 7 pm

Bertken Bar Stock Spinners \$13.50

Lets put your Ad here !

Contact Bill Hager for
Price & availability

BOB REUTHER



HOBBY WORLD Inc.

Quality R. C. Products

6602 Hwy. 100 • Nashville, Tenn. 37205

356-1225



"MATCHED PERFORMANCE SYSTEMS"
K & B ENGINES • K & B FUELS • K & B GLOW PLUGS

"MATCHED FINISH SYSTEMS"
K & B SUPER POXY PAINTS • K & B FIBERGLASS
K & B SUPER POXY RESIN
K & B MICRO BALLOONS FILLER

12152 SO. WOODRUFF AVE., DOWNEY, CALIF. 90241

Matt Smith
NMPRA News Release Editor
10223 Abraham
Dallas, Texas 75227

FIRST CLASS

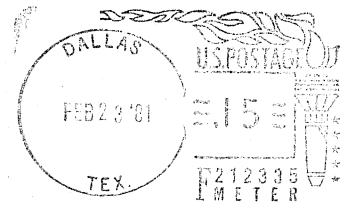

TO:

Ed E. Rankin
6072 Wonder Dr.
Ft. Worth, Texas 7613